

EOCR-SS

Static & electronic over current relay developed to resolve the drawbacks of previous thermal/induction relays



Advanced

- Micro compact size
- Protection against over current/phase loss/locked rotor (phase loss/locked rotor operates by over current)
- Separate setting for startup delay/operation delay time
- Relay resistant to vibration and short-circuit applied (1 a1b applied) * 1 c for standard type
- Integrated AC/DC operating power supply (Free voltage) * AC 100~240V for standard type
- Operation display and active current check (LED)
- Manual (instant)/electrical reset
- Capable of protecting the motor with precisely applied MCU
- N Type, R Type Integration (can select Dip switch) * R-type only for standard type
- NVR (No Volt Release) function / Fail Safe
- Super power-saver and strong environmental resistance

Usage

- Under voltage induction motor (600V)/High voltage motor(3.3kV) protective relay (uses high voltage CT)
- Shock relay by specialized machine
- Current relay for fault monitoring
- For replacement of thermal protective relay

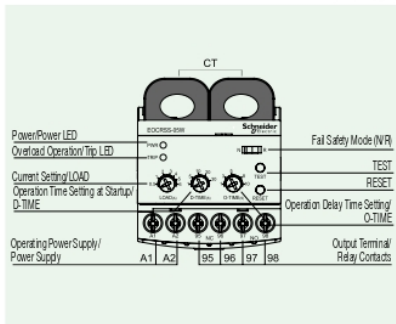

Protection Function

Protected Items	Operation Time
Over Current	O-TIME
Phase Loss	O-TIME
Locked Rotor	O-TIME + D-TIME

LED

Current System Functions Detailed Setting	With current setting, the LED flickers when the current indicator of the setting knob is at 100% of the active load current. This means that it is possible to proceed with the setting after checking the active current, and a setting of up to 103% is possible.
Operation/Operation Display	Relay Operation: Red Power Supplied/Normal operation: Green

Manual (Instant) Reset/Electrical Reset

Press the RESET button or cut the power (L1, L2) - install SW. in remote locations, remote reset function available

Setting

Set as follows after completing the installation.

Category	Setting Knob	Method
Start Delay Time	D-TIME	Turn the D-TIME Knob to set it based on the startup time of the motor
Operation Time	O-TIME	Turn the O-TIME Knob to set at the desired operation time
Current	LOAD	1. After starting the motor, gradually turn the LOAD Knob counterclockwise from the max. value to find the spot at which the LED begins to flicker (active current point) 2. To set to 103%, turn the Knob clockwise to find a spot where the LED is turned off - If this method seems inconvenient, simply set it to 110%~125% of the active current value (item 1).

TEST Method

- After all wiring tasks are complete, if control power is supplied and the Test button is pressed and held, the red LED will illuminate. If the output contact operates when the set D-TIME and O-TIME elapse, it is working properly, and its operating status is normal.
 - Press the Reset button or cut the control power to immediately reset.
 - If the control power functions properly, but the green LED does not, repair service is required.
- ※ Test function is available only after the motor has stopped.

Operation Display

Condition		PWD LED		TRIP LED
Power Supply	Flicker		Lights-out	
In Operation	Flicker		Flicker	
Normal operation	Lights-on		Lights-out	
In Overload	Lights-on		Lights-on	
Upon operation/trip	Lights-out		Lights-on	



Standard

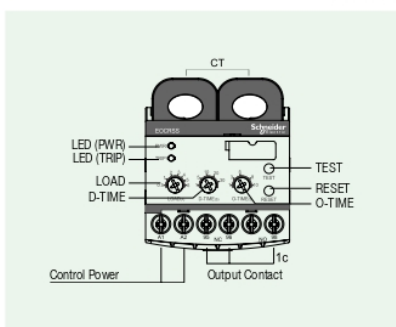

EOCR-SS

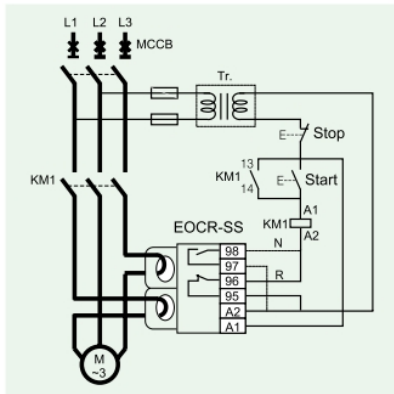

※ "N" (Fail safe) Type converts 95→96 to open and 95→98 to close when operating power is supplied to A1 and A2 (or L1 and L2).

Specifications

Current Setting		Type	Setting Range	
		5	0.5 ~ 6A	
		30	3.0 ~ 30A	
		60	5.0 ~ 60A	
Time Setting		Start Delay Time	D-TIME 0.5 ~ 30 sec	
		Operation Time	O-TIME 0.5 ~ 10 sec	
		Re set Manual (Instant)/Electrical (Remote) Reset		
Operation Time Characteristic		Definite		
Error Tolerance		Current	±10%	
		Time	±15%	
Operating Power Supply	Voltage	S (advanced)	24~240V AC/DC	
		W (advanced)	380~480V AC	
		U (standard)	100~240V AC/DC	
		Frequency	50/60Hz	
Auxiliary Contact	Format	Advanced: 2-SPST (1a1b), Standard: 1-SPDT (1c)		
	State	R Type	Normally de-energized (regardless of power supply: 95-96 Close, 97-98 Open)	
		N Type	Normally energized (after power is supplied: 95-96 Open, 97-98 Close)	
		Rated	AC250V/3A resistive load	
Insulation	Resistance	Between case and circuit	100MΩ or higher with a DC500V Megger	
		Withstanding Voltage	Between case and circuit Between contacts Between circuits	2.0kV power frequency for 1 min 1.0kV power frequency for 1 min 2.0kV power frequency for 1 min
	Usage Environment	Temperature	For storage	-30~80 °C
			For operation	-20~60 °C
		Humidity	30~85% RH with no dew condensation	
Attachment		35mm DIN Rail/Panel		

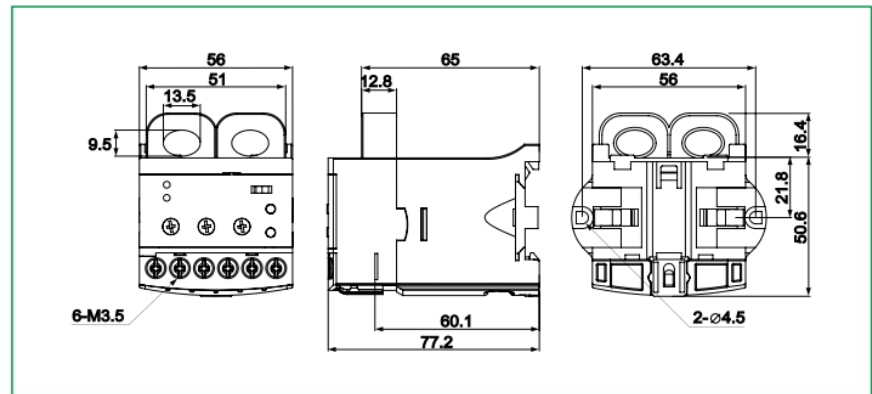

EOCR-SS

How to Order

Reference	Current Range [A]	CT	Output Contact	Operating Power Supply		Notes	
				Voltage [V]	Frequency [Hz]		
EOCRSS Advanced	-05S	0.5~6	-	Select N/R, 2-SPST (1a1b)	AC/DC 24~240V	50/60	For both Panel/DIN rail
	-05W	0.5~6	-	Select N/R, 2-SPST (1a1b)	AC 380~440V	50/60	For both Panel/DIN rail
	-05SQ	0.5~6	-	Select N/R, 2-SPST (1a1b)	AC/DC 24~240V	50/60	For both Panel/DIN rail, product for CCC certification
	-D1S	100:5	100:5	Select N/R, 2-SPST (1a1b)	AC/DC 24~240V	50/60	Rectangular all-in-one 2CT combination
	-DHS	150:5	150:5	Select N/R, 2-SPST (1a1b)	AC/DC 24~240V	50/60	Rectangular all-in-one 2CT combination
	-D2S	200:5	200:5	Select N/R, 2-SPST (1a1b)	AC/DC 24~240V	50/60	Rectangular all-in-one 2CT combination
	-D3S	300:5	300:5	Select N/R, 2-SPST (1a1b)	AC/DC 24~240V	50/60	Rectangular all-in-one 2CT combination
	-D4S	400:5	400:5	Select N/R, 2-SPST (1a1b)	AC/DC 24~240V	50/60	Rectangular all-in-one 2CT combination
	-D1W	100:5	100:5	Select N/R, 2-SPST (1a1b)	AC 380~440V	50/60	Rectangular all-in-one 2CT combination
	-DHW	150:5	150:5	Select N/R, 2-SPST (1a1b)	AC 380~440V	50/60	Rectangular all-in-one 2CT combination
	-D2W	200:5	200:5	Select N/R, 2-SPST (1a1b)	AC 380~440V	50/60	Rectangular all-in-one 2CT combination
	-D3W	300:5	300:5	Select N/R, 2-SPST (1a1b)	AC 380~440V	50/60	Rectangular all-in-one 2CT combination
	-D4W	400:5	400:5	Select N/R, 2-SPST (1a1b)	AC 380~440V	50/60	Rectangular all-in-one 2CT combination
	-30S	3~30	-	Select N/R, 2-SPST (1a1b)	AC/DC 24~240V	50/60	For both Panel/DIN rail
	-30W	3~30	-	Select N/R, 2-SPST (1a1b)	AC 380~440V	50/60	For both Panel/DIN rail
	-30SQ	3~30	-	Select N/R, 2-SPST (1a1b)	AC/DC 24~240V	50/60	For both Panel/DIN rail, product for CCC certification
	-60S	5~60	-	Select N/R, 2-SPST (1a1b)	AC/DC 24~240V	50/60	For both Panel/DIN rail
	-60W	5~60	-	Select N/R, 2-SPST (1a1b)	AC 380~440V	50/60	For both Panel/DIN rail
-60SQ	5~60	-	Select N/R, 2-SPST (1a1b)	AC/DC 24~240V	50/60	For both Panel/DIN rail, product for CCC certification	
EOCRSS Standard	-05RU	0.5~6	-	R type, 1-SPDT (1c)	AC/DC 100~240V	50/60	For both Panel/DIN rail
	-30RU	3~30	-	R type, 1-SPDT (1c)	AC/DC 100~240V	50/60	For both Panel/DIN rail
	-60RU	5~60	-	R type, 1-SPDT (1c)	AC/DC 100~240V	50/60	For both Panel/DIN rail
	-D1RU	100:5	100:5	R type, 1-SPDT (1c)	AC/DC 100~240V	50/60	Rectangular all-in-one 2CT combination
	-DHRU	150:5	150:5	R type, 1-SPDT (1c)	AC/DC 100~240V	50/60	Rectangular all-in-one 2CT combination
	-D2RU	200:5	200:5	R type, 1-SPDT (1c)	AC/DC 100~240V	50/60	Rectangular all-in-one 2CT combination
	-D3RU	300:5	300:5	R type, 1-SPDT (1c)	AC/DC 100~240V	50/60	Rectangular all-in-one 2CT combination
	-D4RU	400:5	400:5	R type, 1-SPDT (1c)	AC/DC 100~240V	50/60	Rectangular all-in-one 2CT combination

EOCR-SS

•Accessory

Accessory1			
Model	Reference	CT Current Transformer Ratio	Notes
2CT	2CT-D1-100-C	100:5	Rectangular 2CT
	2CT-D2-200-C	200:5	Rectangular 2CT
	2CT-D3-300-C	300:5	Rectangular 2CT
	2CT-D4-400-C	400:5	Rectangular 2CT

Ordering Example

e.g., To order an EOCR-SS:

E O C R S S - 0 5 S Advanced
① ②

①	Current Setting Range	5	0.5-6A	For 60A or higher, combine 05Type and an external CT (secondary 5A) for use
		30	3.0-30A	
		60	5.0-60A	
②	Operating Power Supply	S	24-240V AC/DC	
		W	380-440V AC	

※For a CT combination type, please write an accessory code from the CT Order Codes separately.

E O C R S S - 0 5 R U Standard
① ② ③

①	Current Setting Range	5	0.5-6A	For 60A or higher, combine 05Type and an external CT (secondary 5A) for use
		30	3.0-30A	
		60	5.0-60A	
②	Output Power	R	R Type	
③	Operating Power Supply	U	100-240V AC/DC	

※Contacts are 2-SPST (1a1b) for advanced and 1-SPDT (1c) for standard.

e.g., To order a 2CT:

2 C T - D 1 - 1 0 0 - C
①

①	CT Current Transformer Ratio	D1	100	Rectangular 2CT 100:5
		D2	200	Rectangular 2CT 200:5
		D3	300	Rectangular 2CT 300:5
		D4	400	Rectangular 2CT 400:5